

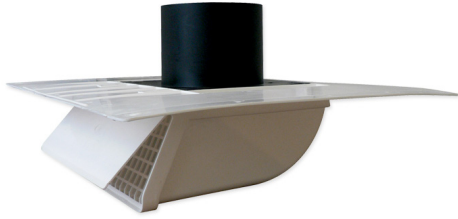

Builder's Best, Inc.
 201 Broiles Drive
 Jacksonville, TX 75766
 903-586-8283
 sales@buildersbest.com
 BuildersBest.com

PRIMEX SV28 SERIES EAVE (SOFFIT) INTAKE/EXHAUST VENT



SV2801 SHOWN ABOVE WITH
 ADAPTER SOLD SEPARATELY PG 22

PRODUCT SPECIFICATIONS PLEASE SEE REVERSE FOR CURRENT PRIMEX TECH SPECS

- UV stabilized polymer resin
- One piece design
- Removable screen
- Removable damper
- Installs flush or with optional snap-in adapter

PART NUMBERS

Part numbers shown are stocked.
 Other Primex items are special orders.

Dia.	Tail	Color	Screen	Old #	New Case #	Qty	Package
4"-8"	n/a	White	removable 1/2" x 1/2"	111941	SV2801	6	Bulk

DIMENSIONS

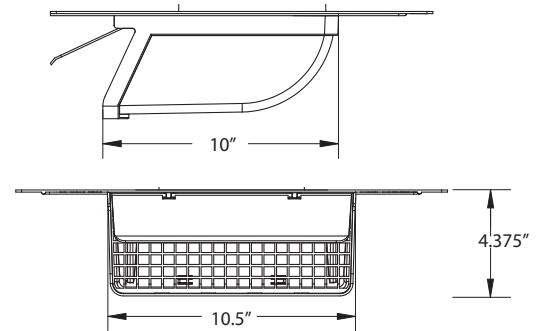
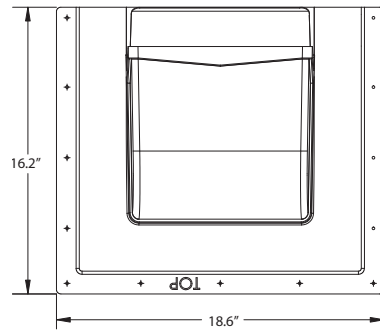
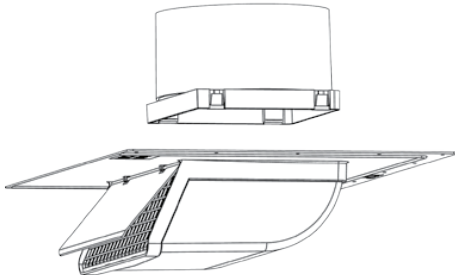

OPTIONAL SNAP-IN ADAPTER

Dia.	Color	Old #	New PN	Qty	Package
4"	black	111787	RV28-4	30	Bulk
5"	black	111788	RV28-5	30	Bulk
6"	black	111789	RV28-6	25	Bulk
7"	black	111790	RV28-7	25	Bulk
8"	black	111791	RV28-8	18	Bulk

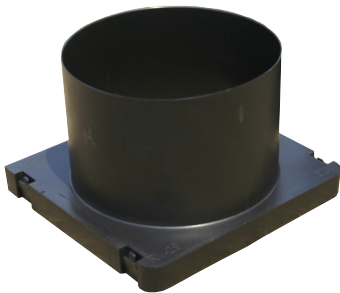

4" Diameter:

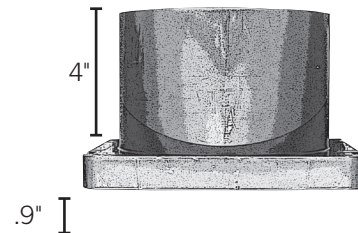
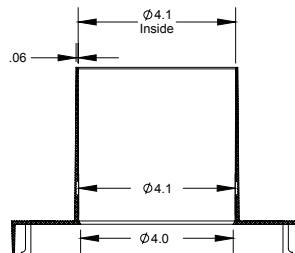

LABELS

Builder's Best is an
 Authorized Primex Distribution Partner
 Primex is Made in Canada by Menzies Group



WARRANTY

Please contact hvac@menzies-metal.com for warranty information.

Hood Eave SV28 spec sheet V7 6/30/23

SV28 Series Soffit Intake/Exhaust Vent

Technical Data Sheet

FEATURES & BENEFITS

- Low profile, one-piece molded hood eliminates leaky joints and provides maximum water protection.
 - Vents odor and moisture away from the home.
 - Optional screen and removable damper.
 - Available for intake or exhaust applications.
 - Snap-in adapters ensure a tight seal.
 - Quick and easy to install.
 - Made with UV-protected polymer resin.
- * For dryer applications we recommend the no screen 'NS' model.

PRODUCT DIMENSIONS

HOOD SIZE: H: 10" / W: 10.5" / D: 4.375"

COLOURS

- Snow White (01)
- Black (25)
- Dark Grey (28)
- Taupe (23)
- Light Grey (31)

APPLICATIONS

- Dryer Venting
- Bathroom Venting
- Range Venting
- Heat Recovery Venting (HRV)
- Intake

PART NUMBER/SIZING

Part #	Size	Free Area	Description	Pkg
SV28		27.8 sq. in.	With screen	6/box
SV28NS		40.3 sq. in.	w/o screen	6/box
ADAPTER				
RV28-4	4" Dia.	12.6 sq. in.	4" Adapter	30/box
RV28-5	5" Dia.	19.6 sq. in.	5" Adapter	30/box
RV28-6	6" Dia.	27.8 sq. in. 28.3 NS	6" Adapter	25/box
RV28-7	7" Dia.	27.8 sq. in. 38.5 NS	7" Adapter	25/box
RV28-8	8" Dia.	27.8 sq. in. 40.3 NS	8" Adapter	18/box

TECHNICAL DRAWING

